

MUN12AD03-SEC EVB Guide

DESCRIPTION:

The evaluation board is for the MUN12AD03-SEC, high efficiency DC/DC power module. The evaluation board generates a +5.0V output voltage at load currents up to 3A. The output voltage can be programmed by the dividing resistor (R_{FB_T} and R_{FB_B}). The MUN12AD03-SEC switches at 1MHz and achieves up to 91% efficiency with the supplied components.

ELECTRICAL SPECIFICATION:

Parameters	Symbol	Value	Unit
Input Voltage Range	VIN	4.5~17	V
Output Voltage	VOUT	1.0~5.0	V
Output Current	IOUT	3	A

EVALUATION BOARD & EFFICIENCY::

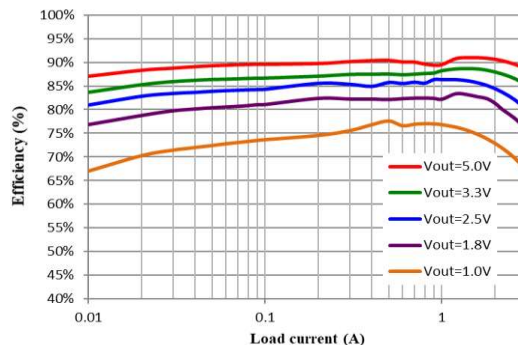
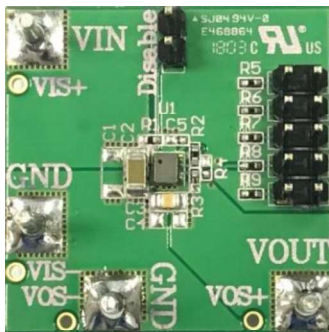

QUICK START:

The module has an internal $0.8V \pm 1.5\%$ reference voltage. The output voltage can be programmed by the dividing resistor (R_{FB_T} and R_{FB_B}). The output voltage can be calculated by Equation 1, resistor choice may be referred to TABLE 1.

$$VOUT(V) = 0.8 \times \left(1 + \frac{R_{FB_T}}{R_{FB_B}} \right) \quad (EQ.1)$$

TABLE 1 Resistor values for common output voltages

VOUT	1.0V	1.2V	1.5V	1.8V	3.3V	5.0V
R_{FB_T} (Ohm)	124k	124k	124k	124k	124k	124k
R_{FB_B} (Ohm)	499k	243k	140k	100k	39.2k	23.7k

MUN12AD03-SEC EVB Guide

EVALUATION BOARD SCHEMATIC:

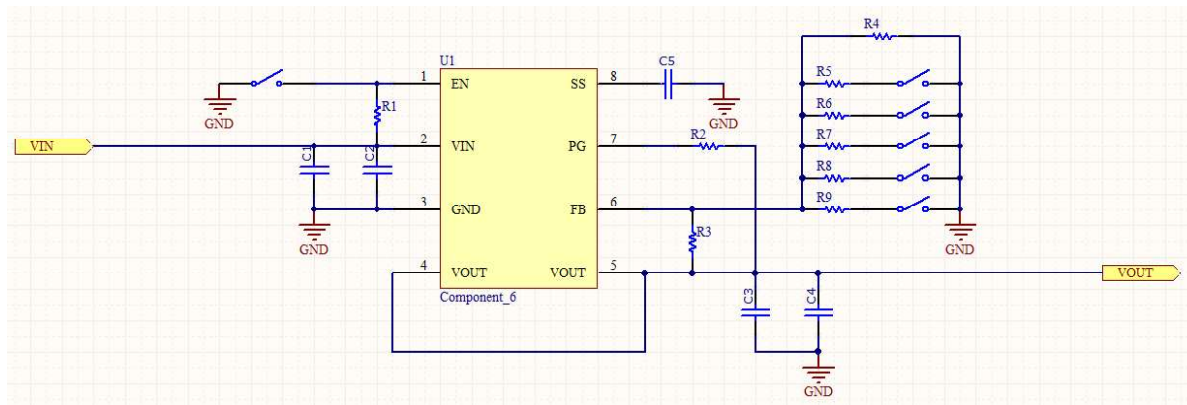

BILL OF MATERIALS:

COUNT	REF DES	DESCRIPTION	PART NUMBER	MFR
1	C2	MLCC,10uF/25V 1206 X5R	TMK316BBJ226ML-T	Taiyo
2	C3,C4	MLCC,22uF/10V 0805 X7R	GRM21BZ71A226ME15L	Murata
0	C1,C5	DXP		
3	R1,R2,R7	Resistor,100k Ohm,±1%,0402	Std	Cyntec
1	R3	Resistor,124K Ohm,±1%,0402	Std	Cyntec
0	R4	DXP		
1	R5	Resistor,499k Ohm,±1%,0402	Std	Cyntec
1	R6	Resistor,243k Ohm,±1%,0402	Std	Cyntec
1	R8	Resistor,39.2k Ohm,±1%,0402	Std	Cyntec
1	R9	Resistor,23.7k Ohm,±1%,0402	Std	Cyntec
1	U2	Power module, 3.0*2.8*1.5mm	MUN12AD03-SEC	Cyntec